

TOTO®

SW3046T40

WASHLET®+ S500e – Contemporary ELONGATED

FEATURES

- Concealed supply connection for seamless installation
- Gentle Aerated, Warm Water, Dual Action Spray with oscillating and pulsating feature
- Adjustable water temperature and volume
- Instant water heating system for continuous warm water and energy saving
- Warm air drying with five variable temperature settings
- Automatic air deodorizer
- Convenient slim wireless remote, with illuminated touch pad
- 2 saved user settings
- Docking station for easy cleaning and installation
- Heated Seat with Temperature Control
- eWater+ auto-cleans wand and bowl
- On-demand remote function cleans wand with ewater+
- Water pre-mist of bowl before each use



MODELS

- SW3046T40 - Contemporary Design

COLORS/FINISHES

- #01 Cotton

PRODUCT SPECIFICATION

Seat shall have gentle aerated, warm water, dual action spray with cycling movement and massage feature. Seat shall have adjustable water temperature and volume. Seat shall have warm air drying with five variable temperature settings. Seat shall have automatic air deodorizer. Seat shall include wireless remote control. Seat shall be solid plastic with closed front seat and cover. Seat shall include power cord, and water supply hoses. eWater+ cleans the bowl and wand. Seat shall be model # SW3046T40

CODES/STANDARDS

- Meets and exceeds ASME A112.4.2, ASME A112.18.1/CSA B125.1, UL 1431, CSA C22.2 #68
- Certifications: IAPMO(cUPC), State of Massachusetts, City of Los Angeles and others
- Code Compliance: UPC, IPC, NSPC, NPC Canada, and others



SW3046T40

WASHLET+ S500e – Contemporary ELONGATED

SPECIFICATIONS

Power Rating	AC 120 V 60 Hz
Power Consumption	1288W
Max Power Consumption	1444W
Power Cord Length	3.94 ft (1.2 m)
Spray Volume	Rear Cleansing: 0.08 – 0.11 gal/min Rear Soft Cleansing: 0.08 – 0.11 gal/min Front Cleansing: 0.08 – 0.11 gal/min Wide Front Cleansing: 0.08 – 0.11 gal/min
Spray Features	Adjustable Surface Temp: 86 – 104 °F (30 – 40 °C) Safety Device: Temperature Fuse
Warm Air Dryer Features	Adjustable Air Temp: 95 – 140 °F (35 – 60 °C) Airflow Volume: 10.24 ft ³ /min (0.29 m ³ /min) Safety Device: Temperature Fuse
Heated Seat Features	Adjustable Surface Temp: 82 – 97 °F (28 – 36 °C) Safety Device: Temperature Fuse
Water Supply Pressure	Minimum: 7.25 PSI (Dynamic) Maximum: 108.75 PSI (Static)
Ambient Temp.	32 – 104 °F (0 – 40 °C)
Warranty	One Year Limited Warranty
Shipping Weight	SW3046T40: 15.6 lbs
Shipping Dimensions	SW3046T40: 23-3/4" L x 17"W x 9-1/2"H

INSTALLATION NOTES

- WASHLET+ S500e is designed to fit TOTO WASHLET+ bowls only
- If possible, with your order, please include your model number (from the underside of the tank lid).
- It is highly recommended to use a surge protector to prevent damage in the event of a power surge.
- For use with potable water only. Do not use with recycled water.
- Warning: Rated power consumption 1288W

DIMENSIONS

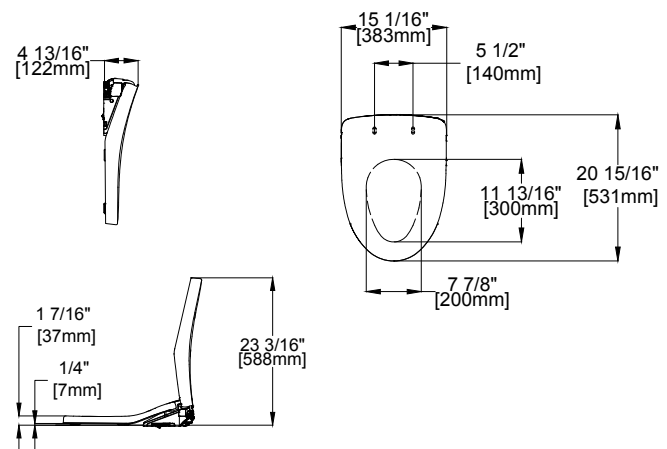

TOTO

These dimensions and specifications are subject to change without notice

Ph: (888) 295-8134 | Fax: (800) 699-4889 | www.totousa.com | © TOTO USA

SS-01334 v.03